

Swallow Series

IN FLEXIBILITY, DESIGN AND COMFORT

MODERNSOLID

LCD Monitor Arm

Swallow Series
FLEXIBILITY • SPACE • ERGONOMICS

Single
Monitor
Arm



Dual
Monitor
Arm



DISPLAY
MOUNTS
2018



Wall
Mount



Multi
Monitor
Arm

MODERNSOLID INDUSTRIAL CO., LTD.

NO.11-2, Wu Nan Rd., Wu Chi Dist., Taichung City 435, Taiwan.
TEL: 886-4-26397717 / 886-4-26398669 (Rep.) / FAX: 886-4-26398333
Website: www.modernsolid.com / E-mail: info@modernsolid.com.tw

2018.10



MODERNSOLID

www.modernsolid.com

Company Profile



MODERNSOLID, an ISO 9001 approved manufacturer, supplies since 1988 a wide range of Mounting Solutions that accommodates large and small displays for office, education, industrial, and healthcare market, etc.

As an awarded innovative company, **MODERNSOLID** keeps on top of the latest market trends and research in the technology field, and is dedicated to helping our partners find the best solution. We offer an entire range of products tailored to any market opportunities.

We support our customers in growing their business with innovative, high quality engineering products and years of manufacturing experience.

Contact us and let us support your growing business with **MODERNSOLID**-Products!

Contents

Swallow Series

03 Desk Mount - FA-200 Series

Single Monitor Arm
Dual Monitor Arm
Multi Monitor Arm

05 Desk Mount - FA-500 Series

Adjustable Configurations
Single Monitor Arm
Converting to Multiple Monitor Application

09 Wall Mount

Wall Mount

10 Quick-release Attachment Options

Quick-release Attachment Options

Desk

Mount FA-200 Series



Single Monitor Arm

- With few parts, it features a slim and streamlined design.
- Easy height, tilt and swivel adjustment for viewing comfort.
- The sturdy main frame can still move smoothly under heavy load.
- Simple and efficient cable management



Simple Height adjustment

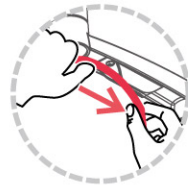

Neat Cable management

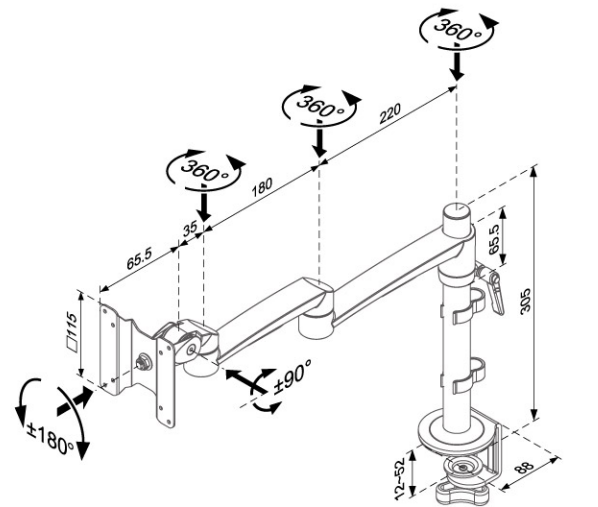

unit:mm

FA-201

VESA 75/100mm
max ~14kg (30.8lbs)

Dual Monitor Arm

- Sturdy design made of high quality aluminum alloy.
- Dual-monitor application enables greater productivity.
- Organized cable management gives a neat look.
- The monitors can be positioned side-to-side or back-to-back.

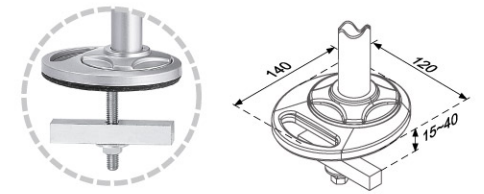

FA-225 Grommet Type



FA-215

VESA 75/100mm
max ~28kg (61.6lbs)

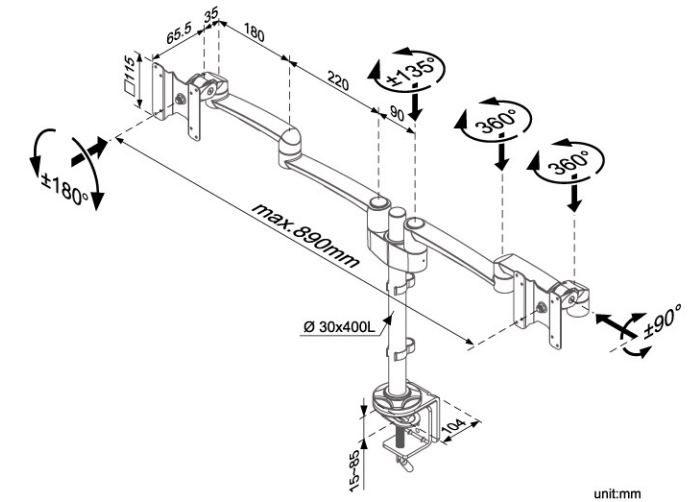

unit:mm

Multi Monitor Arm

- Sturdy design made of high quality aluminum alloy.
- For the Multiple screen needed such as security monitoring, trading desk, gaming applications.
- Organized cable management gives a neat look.
- The monitors can be positioned side-to-side or back-to-back.

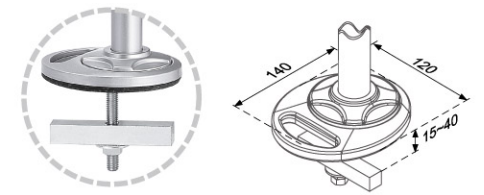

FA-227 Grommet Type



FA-217

VESA 75/100mm
max ~36kg (79.2lbs)

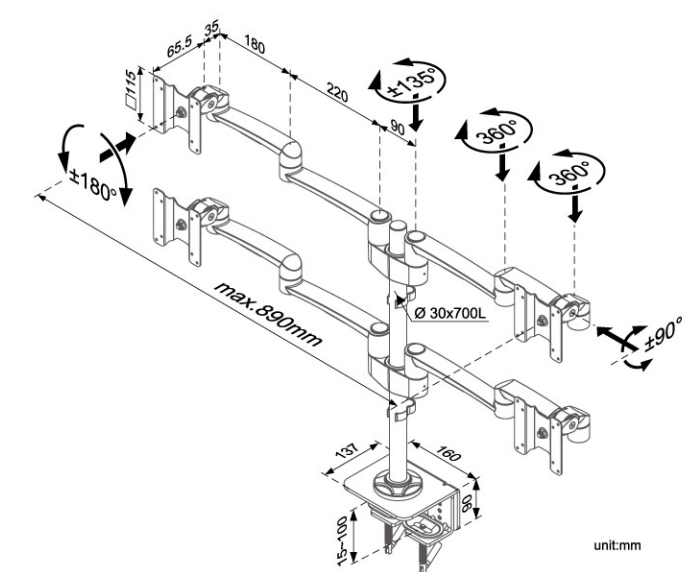

unit:mm

Desk

Mount FA-500 Series



Adjustable Configurations

- Easy height adjustable for viewing comfort.
- The monitor can be pushed out of the way when not in use for space saving.
- Well cable management gives a clean appearance.
- Stable design with smoothly moving under heavy loading.

Arm



Attachment Options

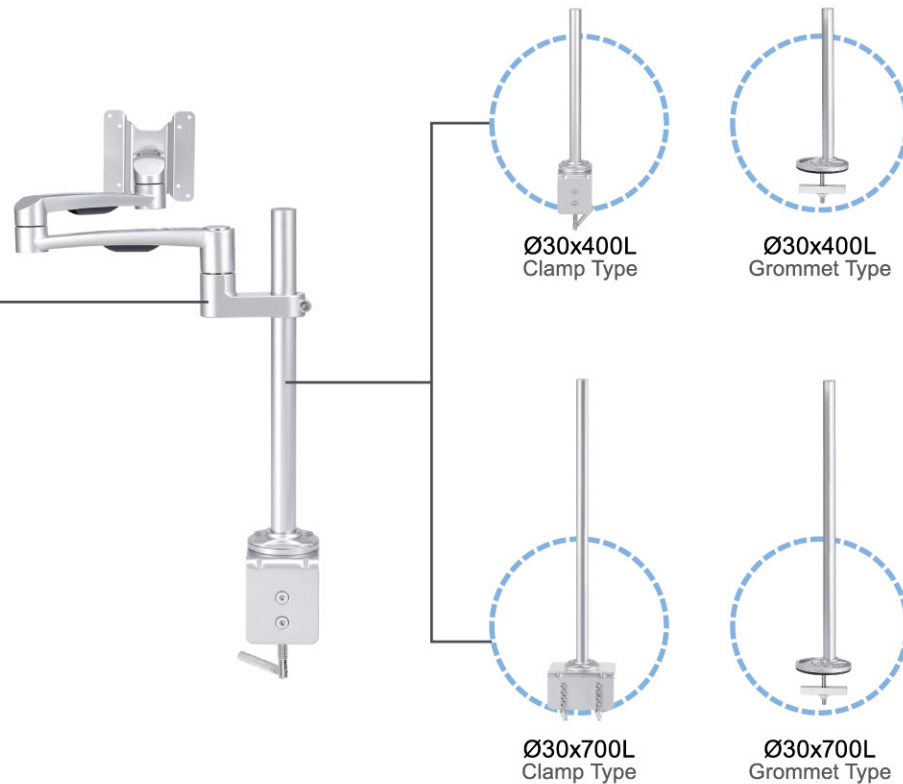

Single Monitor Arm

- Additions to arm length can be made easily to provide extended reach.
- Organized cable management provides a neat look.
- Enables comfortable viewing for display mounted on the desk.
- Height-adjustable design enhances comfort with a specific.

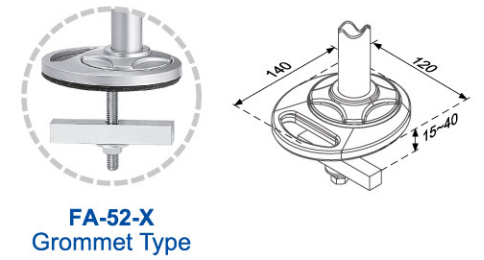

FA-51-1

VESA 75/100mm
max ~14kg (30.8lbs)

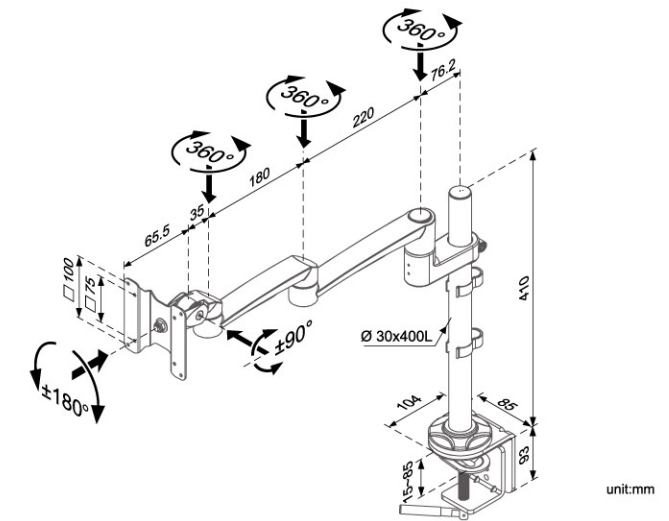

FA-51-2

VESA 75/100mm
max ~14kg (30.8lbs)

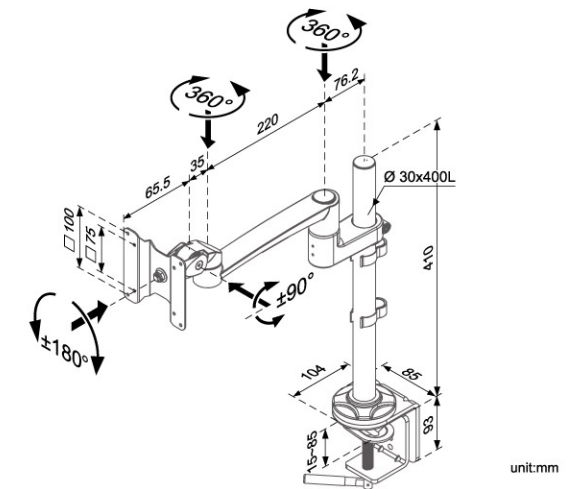

FA-51-3

VESA 75/100mm
max ~14kg (30.8lbs)

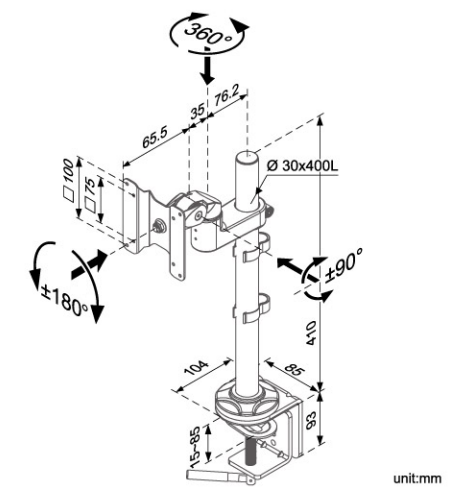

▶▶ Converting to Multiple Monitor Application

- Easy converting to multiple monitor application.
- Allows the merger of form and function with one product.
- The monitors can be positioned side-to-side or back-to-back.

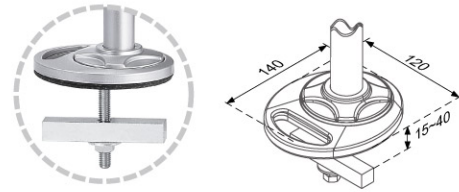

FA-52X-1
Grommet Type



FA-515-1
VESA 75/100mm
max ~28kg (61.6lbs)

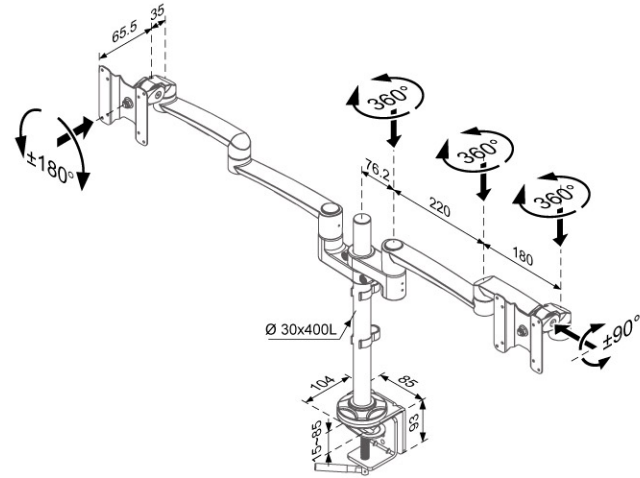

unit:mm

▶▶ Converting to Multiple Monitor Application



FA-517-1
VESA 75/100mm
max ~36kg (79.2lbs)

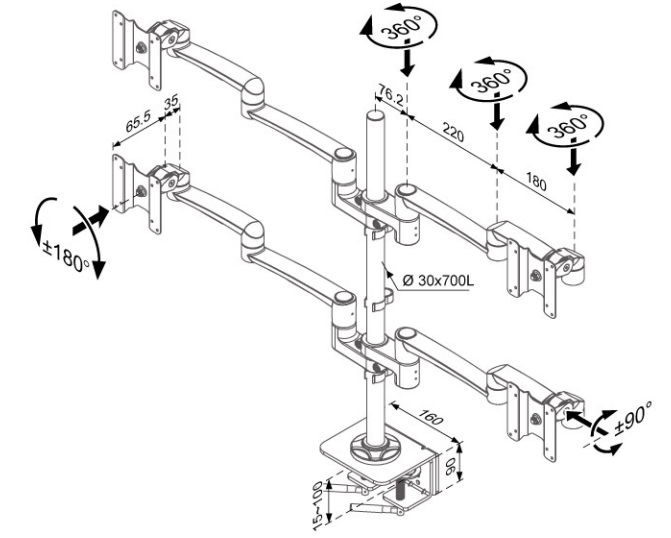

unit:mm



FA-516-1
VESA 75/100mm
max ~28kg (61.6lbs)

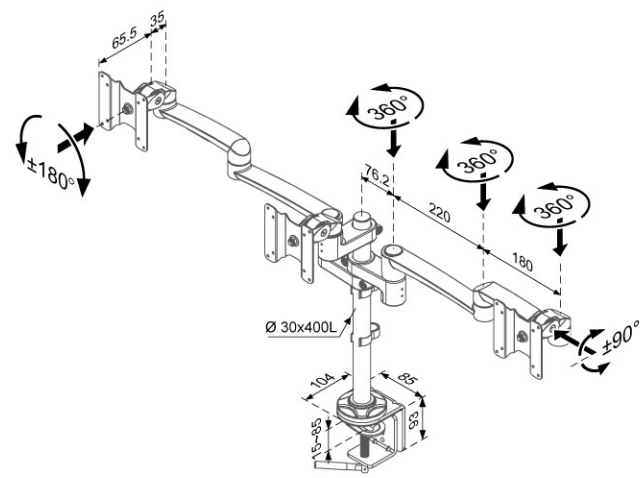

unit:mm

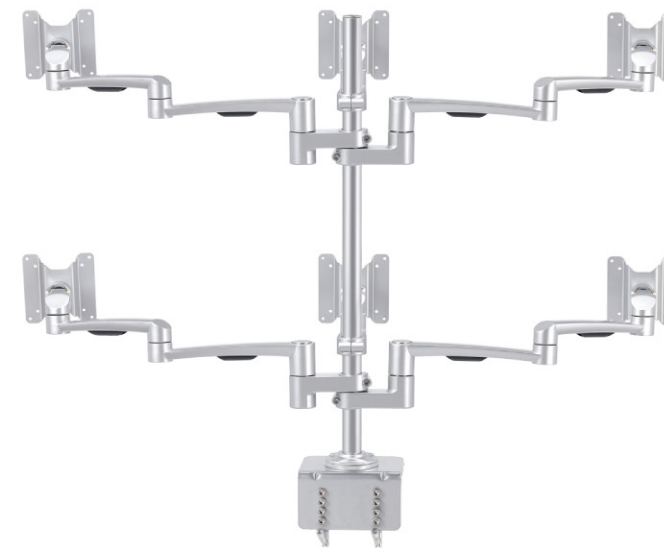

FA-518-1
VESA 75/100mm
max ~36kg (79.2lbs)

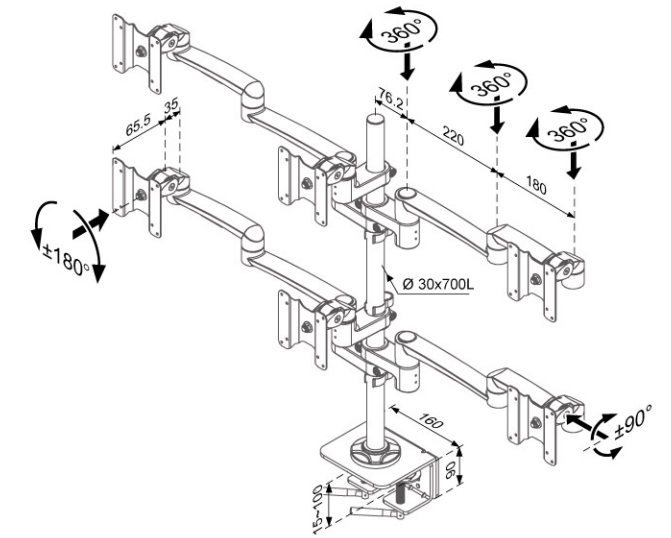

unit:mm

Wall Mount



Wall Mount

- Wall mounted to maximize use of all available space.
- It features slim profile and light weight design.
- Increase viewing comfort-help reduce eye, back and neck strain.
- Push the monitor out of the way when not in use.



Neat Cable management

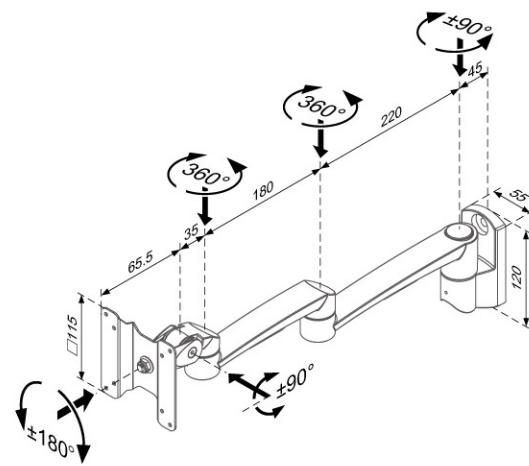

unit:mm

FA-251

VESA 75/100mm
max ~14kg (30.8lbs)

Quick-release Attachment Options

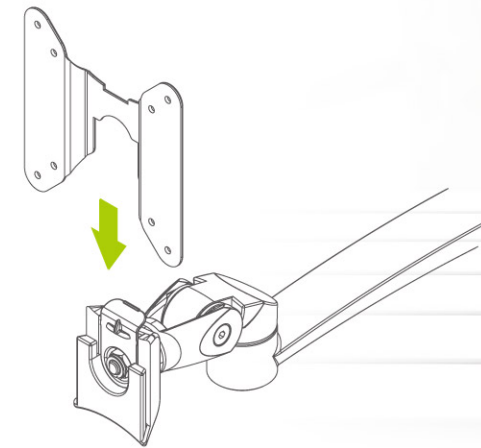

Quick-release Attachment Options

- Quick-release VESA enables easy installation.
- The sturdy main frame is moving smoothly even under heavy load.
- Allows effortless adjustment for viewing comfort.

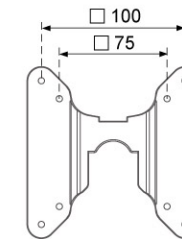
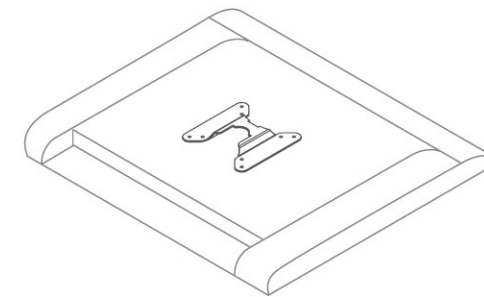

FA-201A
VESA 75/100mm
max ~14kg (30.8lbs)



FA-215A
VESA 75/100mm
max ~28kg (61.6lbs)



FA-217A
VESA 75/100mm
max ~36kg (79.2lbs)



FA-251A
VESA 75/100mm
max ~14kg (30.8lbs)